

Thomson WhisperTrak™ Electric Linear Actuator

Installation Manual

Edition 2018-01

DW110685-GB-1803



Version History

Edition	Reason for revision
2011-06	First edition.
2012-05	4000 N model added and updated safety information.
2012-08	High speed version added.
2013-04	General technical update, changed page count, updated address list.
2013-07	Rewritten Electrical Installation section. Drawings and diagrams removed.
2016-05	New control options added. Updated some technical data and address list.
2017-01	Operation temp. for 4000 N changed. Performance and temp. derate diagrams added. Slow blow added to fuse table. Safety nut info. and cleaning recommendations added.
2017-03	Certifications line changed and ETL note added to table on page 12.
2017-05	Slow blow removed from fuse text and table on page 8.
2017-05:2	Molex connector wiring table changed.
2018-01	Sentence changed to “** Channel A leads channel B when extending“ on page 11.

Warranty

The Thomson WhisperTrak™ is warranted to be free from defects in materials and workmanship for a period of twelve (12) months from date of delivery. The application of this product is the responsibility of the buyer and Thomson makes no representation or warranty as to the suitability of the product for any particular use or purpose. For a copy of the entire warranty for this product that is contained in our standard terms and conditions of sale, please go to http://www.thomsonlinear.com/website/com/eng/support/terms_and_conditions.php.

Disclaimer

Technical changes to improve the performance of the equipment may be made without prior notice!

All rights reserved. No part of this work may be reproduced in any form (by printing, photocopying, microfilm or any other method) or processed, copied or distributed by electronic means without the written permission of Thomson.

Contents

1. General 4

- 1.1 About this manual 4
- 1.2 Target group 4
- 1.3 Symbols used 4
- 1.4 Transport and storage 4
- 1.5 Packaging 4
- 1.6 Disposal 4
- 1.7 Support 4

2. Safety 5

- 2.1 Safety notes 5

3. Standards 5

- 3.1 EC Declaration of conformity 5

4. Installation 6

- 4.1 Name plate 6
- 4.2 Terminology 6
- 4.3 Operation environment 6
- 4.4 Mechanical installation 7
- 4.5 Electrical installation 8

5. Technical specifications 12

- 5.1 Technical data 12
- 5.2 Performance diagrams 13
- 5.3 Safety nut information 14
- 5.4 Cleaning 14
- 5.3 Type designation key 15

1. General

1.1 About this manual

This manual describes how to install the Thomson WhisperTrak™ electric linear actuator both mechanically and electrically. It also contains, among other things:

- technical data
- dimensional drawings
- type designation key.

It is important to carefully read this manual before installing the actuator and to have the correct qualifications needed to perform the installation.

1.2 Target group

This manual addresses qualified mechanical and electrical personnel.

1.3 Symbols used



This symbol is shown to highlight a general warning, general instruction or as a warning for a mechanical hazard.

1.4 Transport and storage

The actuator may only be transported and stored in the original packaging supplied by Thomson. The temperature during transportation and storage must be between -25 to +40 °C (-13 to +104 °F). Avoid shocks to the package. If the package is damaged, check the actuator for visible damage and notify the carrier, and if appropriate also Thomson.

1.5 Packaging

The packaging consists of a cardboard box. The box contains the actuator and this manual.

1.6 Disposal

Where required by law, used packaging and actuators are taken back by Thomson for professional disposal if the transportation cost is taken over by the sender. Please contact Thomson for information on where to ship it.

1.7 Support

In case you need technical support or any information related to this product, please contact the nearest Thomson Service Center. See the back of this manual. You can also visit www.thomsonlinear.com for information on this product and how to get in touch with us.

2. Safety

2.1 Safety notes



- Only properly qualified personnel are permitted to perform mechanical and electrical installation on this product. Properly qualified personnel are familiar with mechanical or electrical installation work and that have the appropriate qualifications for their jobs.
- Read this manual and any other available documentation before working on the equipment. that the actuator is or shall be a part of.
- Keep strictly to the data in this manual and on the name plate on the actuator and never exceed the performance limits stated herein.
- Never work on the actuator or its installation with the power on.
- Never unplug any cables or connectors during operation or with power on.
- Immediately stop using the actuator if it seems faulty or broken in any way and notify an appropriate person so that corrective actions can be taken.
- Never try to open the actuator as that will compromise the sealing and the function of the actuator. There are no serviceable components inside.
- Grease may be present on the extension tube. Contact is non-hazardous. Film should not be removed.

3. Standards

3.1 EC Declaration of conformity

We, Tollo Linear AB

Declare that this product corresponds with the directive 2006/42/EC, RoHS directive 2002/95/EC, WEEE directive 2002/96/EC, low voltage directive 2006/95/EC (EN60204-1:2006), directive of electromagnetic compatibility 2004/108/EC (EN55014-1:2006, EN61000-6-3:2007, EN50011, EN55015:2006 & EN55022:2006) and the standard for medical electrical equipment - part 1-2 (EN 60601-1-2 third edition).

Thomson WhisperTrak™

Product

W12(24)xx-xxxxx-xxxx

Description

Can be used when the machine or the system, which it shall be, a part of is in accordance with the demands in the EEC Machinery Directive and/or other relevant regulations.

Kristianstad 2011-01-24

Date

Håkan Persson

Name

Product Line Manager

Title

Signature

4. Installation

4.1 Name plate

The name plate can be found on the actuator housing. It will tell you which model of actuator you have and its basic performance data. Please study the name plate to see what type of actuator you have before starting any installation or service on the actuator. If you need any assistance from Thomson, please tell us the manufacturing date and the designation of the actuator(s) in question.

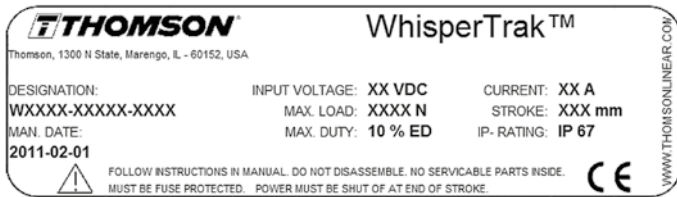

4.2 Terminology

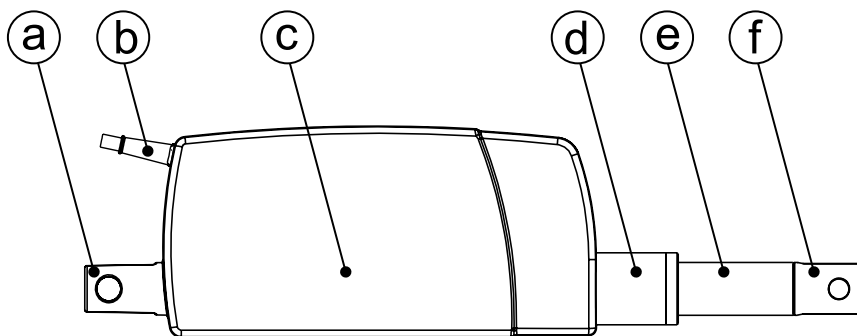

a. rear adapter
b. cable outlet

c. housing
d. cover tube

e. extension tube
f. front adapter

4.3 Operation environment

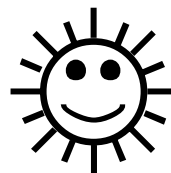

Wxx02-: Min. -25° C (-13° F) Max. +40° C (+104° F) IP67

Operation temperature range is between -25 to +40° Celcius (-13 to +104° Fahrenheit). Two actuator versions with option E will have a reduced load capacity at lower temperatures. See diagram "Load Capacity vs. Operating Temperature" on page 13.

Protection degree against the ingress of water and particles is IP67.

Relative humidity range is 10 - 90 % non-condensing.

4.4 Mechanical installation

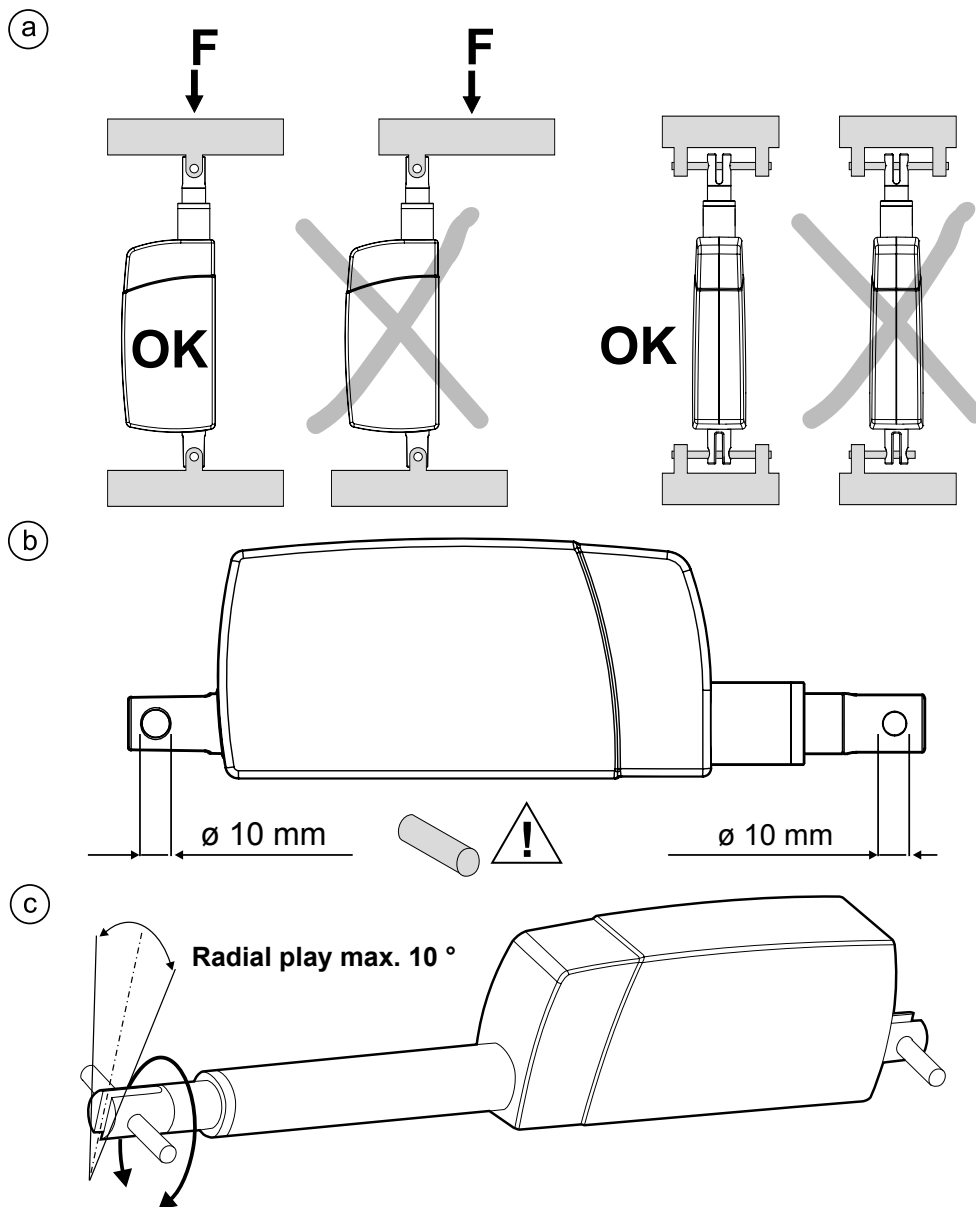

Always install actuator so that the force of the load acts in the center of the extension tube and the rear adapter and support the mounting pins at both ends (a). Only mount the actuator to the rear and front mounting adapters using solid pins (b). The mounting pins must be parallel to each other both radially and axially and be supported in both ends.

The actuator is equipped with an anti-rotation mechanism where the moving extension tube is internally restrained from rotating. The maximum radial play allowed by the anti-rotation mechanism in the extension tube is 10 degrees (c).

Failure modes of the actuator should be considered to ensure it does not create harm.

 **Warning!** Do not hold the extension tube while the tube is moving or the unit is energized.

4.5 Electrical installation

4.5.1 General notes



- Make sure the leads/cables leading to the motor can handle the maximum motor current.
- We recommend to include an emergency stop to avoid any crushing hazard.
- Never work on the actuator or the wiring with the power switched on!

4.5.2 Fuse size

Protect the actuator and the wiring by using a fuse between the actuator and the power source. See table below for recommended fuse size.

Recommended fuse size		
Actuator supply voltage	Max. load	Fuse size
12 VDC	2000 N	5 A
12 VDC	4000 N	8 A
24 VDC	2000 N	2 A
24 VDC	4000 N	3 A

4.5.3 Wire cross sections

To avoid malfunction due to voltage drop the cross section of the wires between the actuator motor and the power source must be of sufficient size. For longer cables than stated in the table calculations based on the supply voltage, the current draw, the length of the cables and the ambient temperature must be done.

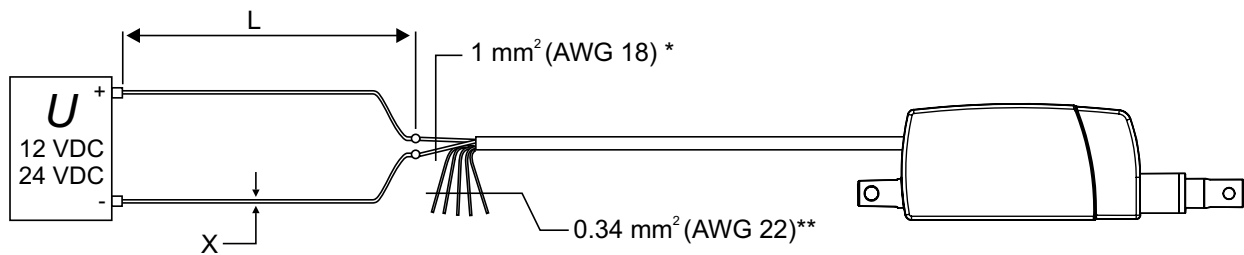

* Leads for motor connections.
 ** Leads for signal/logic connections.

Wire cross sections	
Length of cable (L)	Min. allowed cross section (X)
00 - 10 m	1.0 mm² (AWG 18)
10 - 20 m	1.5 mm² (AWG 14)

4.5.4 Connector wiring configurations

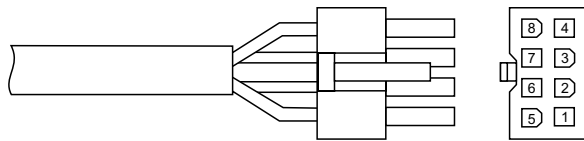

Molex type connector (cable and connector option 3)

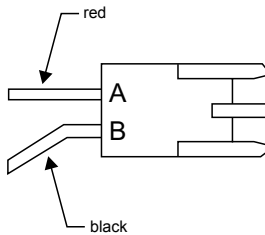

Pac Con type connector (cable and connector option 4)

Molex type connector wiring		
Pin	Option N	Option D
1	black	black
2	-	-
3	-	brown
4	-	orange
5	-	white
6	-	-
7	-	green
8	red	red

4.5.5 Installation of standard actuator with no electrical options (option N) or Electronic Limit Switches (option X)

By switching the polarity of the voltage to the motor the extension tube will change direction. Make sure the switch used can handle the maximum motor current.

Option N: the actuator voltage must be switched off when reaching the ends of stroke or due to a mid-stroke overload to avoid causing damage to the actuator.

Option X: the actuator will automatically switch off when reaching the ends of stroke or a mid-stroke overload.

Wiring diagram for option N and X

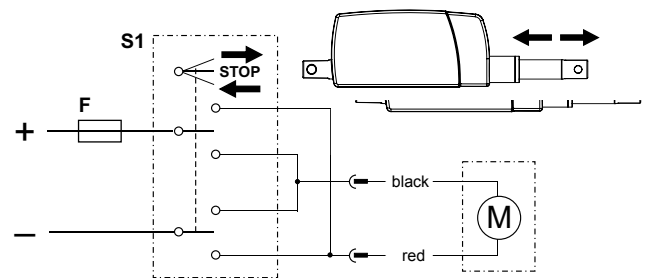

- M Actuator motor
- S1 Double pole double throw (DPDT) switch
- F Fuse

4.5.6 Installation of actuator with Electronic Limit Switches / Low Level Switching (option E)

The direction of the extension tube is controlled by switching the COM (common) output to the EXT (extend) or RET (retract) inputs.

The actuator will automatically switch off when reaching the ends of stroke or a mid-stroke overload.

Two actuator versions with option E will have a reduced load capacity at lower temperatures. They are Wxx02-54AxxxE (2000 N high speed version) and Wxx04-58AxxxE (4000 N version). Also see diagram "Load Capacity vs. Operating Temperature" on page 13.

Wiring diagram for option E

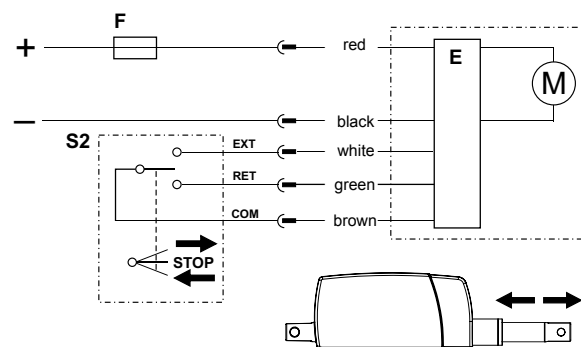

- M Actuator motor
- S2 Single pole double throw (SPDT) switch
- F Fuse
- E Electronic limit switches device

4.5.7 Installation of standard actuator with Analog Feedback (option P) or Analog Feedback + Electronic Limit Switches (option Z)

By switching the polarity of the voltage to the motor the extension tube will change direction. Make sure the switch used can handle the maximum motor current.

Option P: the actuator voltage must be switched off when reaching the ends of stroke or due to a mid-stroke overload to avoid causing damage to the actuator.

Option Z: the actuator will automatically switch off when reaching the ends of stroke or a mid-stroke overload.

Feedback output is most accurate under uni-directional loading when approaching the position from the same direction.

Absolute positioning is affected by load direction and value, clearance in the mounting points, actuator end play, gear backlash, feedback sensor linearity and the control systems capability to control the motor.

To minimize the effects of stroke tolerances, feedback output is calibrated at the factory to provide 2.5 VDC output at the nominal mid stroke position of the actuator (for example at 50 mm for a 100 mm stroke). Applications should be designed for travel between the maximum retract position and the minimum extended length.

The smallest amount of positional movement the analog feedback sensor can detect and reflect is 0.12 mm.

Wiring diagram for option P and Z

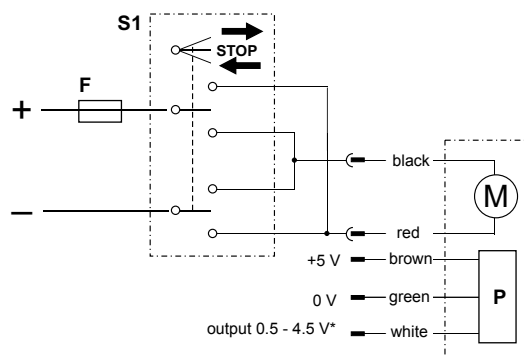

* From 0.5 V at fully retracted (←) to 4.5 V at fully extended (→).



- M Actuator motor
- S1 Double pole double throw (DPDT) switch
- F Fuse
- P Analog feedback device

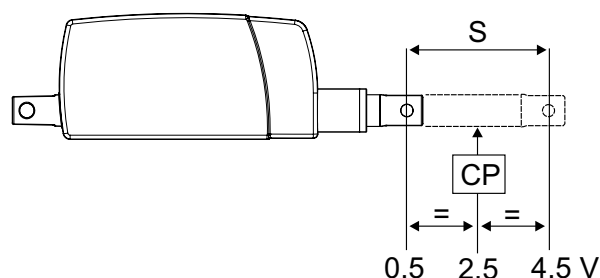

- S Actuator stroke length
- CP Calibration point for analog feedback signal

Analog feedback data	
Actuator stroke length [mm]	Voltage resolution [V/mm]
100	0.040
200	0.020
300	0.0133
400	0.010
500	0.008

4.5.8 Installation of standard actuator with Digital Feedback (option D) or Digital Feedback + Electronic Limit Switches (option Y)

By switching the polarity of the voltage to the motor the extension tube will change direction. Make sure the switch used can handle the maximum motor current.

Option D: the actuator voltage must be switched off when reaching the ends of stroke or due to a mid-stroke overload to avoid causing damage to the actuator.

Option Y: the actuator will automatically switch off when reaching the ends of stroke or a mid-stroke overload.

Feedback output is most accurate under uni-directional loading when approaching the position from the same direction.

Absolute positioning is affected by load direction and value, clearance in the mounting points, actuator end play, gear backlash, feedback sensor linearity and the control systems capability to control the motor.

The digital feedback sensor outputs a two channel quadrature signal which is used to determine the travel direction and to calculate the travel distance. It consists of two rectangular-wave signals that transition from a HIGH to a LOW state every 180 degrees of rotation and the signal transitions of each output are offset by 90 degrees of rotation from each other.

The output type of the sensor is open collector. The output essentially acts as either an open circuit (floating) or a connection to ground. The output usually has an external pull-up resistor, which raises the output voltage when the transistor is turned off. Because the pull-up resistor is external and need not be connected to the chip supply voltage, a lower or higher voltage can be used instead. The pull up resistor needs to be dimensioned and supplied by the customer.

The smallest distance that the sensor can detect and reflect:

- Wxxxx-58A (standard speed): 0.1003 mm
- Wxxxx-54A (high speed): 0.2006 mm

Wiring diagram for option D and Y

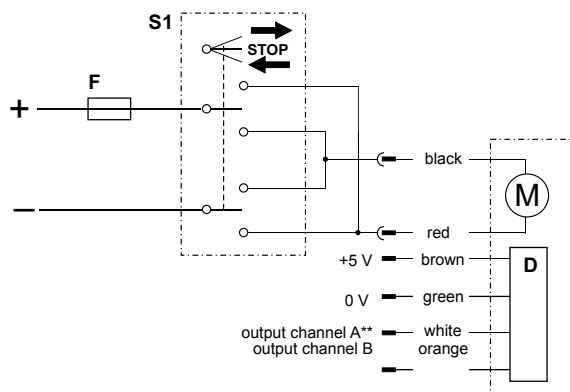

** Channel A leads channel B when extending (→).

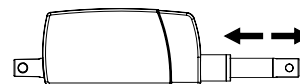

- M Actuator motor
- S1 Double pole double throw (DPDT) switch
- F Fuse
- D Digital feedback device

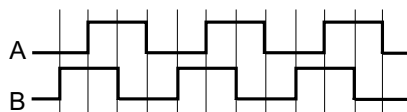

Two channel quadrature signal

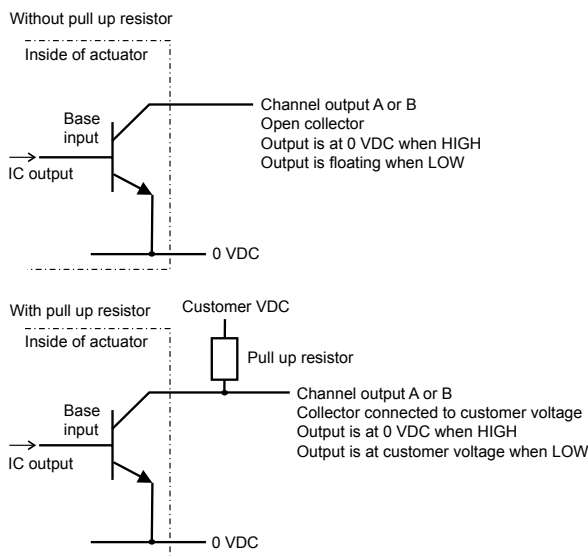

Open collector output with and without pull up resistor

5. Technical Specifications

5.1 Technical data

Technical Specification	Wxx02 (2000 N (450 lbs) Version)				Wxx04 (4000 N (900 lbs) Version)			
Voltage								
Input voltage [VDC]	12		24		12		24	
Load								
Static load (Fx), maximum [N (lbs)]	2000 (450)				4000 (900)			
Dynamic load (Fx), maximum [N (lbs)]	2000 (450)				4000 (900)			
Stroke								
Stroke lengths, standard [cm (inch)]	10 (3.94), 20 (7.87), 30 (11.81), 40 (15.75), 50 (19.69)							
Speed								
Speed version	58A	54A	58A	54A	58A	58A	58A	
Speed, no load [mm/s (inch/s)]	5.8 (0.23)	11.0 (0.43)	5.8 (0.23)	11.0 (0.43)	5.8 (0.23)	5.8 (0.23)	5.8 (0.23)	
Speed, rated load [mm/s (inch/s)]	4.0 (0.16)	8.0 (0.31)	4.0 (0.16)	8.0 (0.31)	4.0 (0.16)	4.0 (0.16)	4.0 (0.16)	
Current								
Current draw @ rated max. load [A]	4.5	9.0	2.2	4.5	9.0	4.5	4.5	
Current draw @ stall/in-rush [A]	14.0	21.0	8.0	11.0	21.0	11.0	11.0	
General data								
End play, maximum [mm (inch)]	0.5 (0.020)							
Operating temperature limits [°C (°F)]	-25 to +40 (-13 to +104) ⁽¹⁾							
Duty cycle, maximum [%]	10							
On-time, maximum [s]	180	90	180	90	90	90	90	
Life, average [cycles]	10 000							
Sound level [dBa]	< 45							
Lead screw type	acme							
Protection class	IP67							
Anti rotation mechanism ⁽²⁾	yes							
Analog feedback output signal voltage [VDC]	0.5 - 4.5							
Analog feedback output signal linearity [%]	0.5							
Digital feedback input voltage [VDC]	3.8 - 24							
Digital feedback output resolution [pulses/mm]	10	5	10	5	10	10	10	
Compliances / Certifications	AAMI STD ES60601-1, IEC STD 60601-1 / CSA STD C22.2 # 60601-1 ⁽⁵⁾							
Options								
<ul style="list-style-type: none"> • Electronic limit switches (ELS) ⁽³⁾ • ELS + low level switching ^{(1) (4)} • Analog or digital position feedback, with or without ELS • Mounting adapters turned 90° 								

1) Thrust is reduced at lower temperatures for 2000 N (450 lbs) high speed (54A) and 4000 N (900 lbs) units with ELS + low level switching (option E), see diagram on page 13.

2) Prevents the extension tube from rotating if it is not fixed in the end.

3) Shuts off power at the end of stroke and all along the stroke at overload conditions. ELS is normally set for 120% of the rated dynamic maximum load.

4) Low level switching allows low level signals to control the actuator movement instead of having to switch the high amperage motor voltage.

5) ETL certification available on N, E, P, and D feedback options only.

5.2 Performance Diagrams

Wxx02-58A - Load vs. Speed / Current
(2000 N (450 lbs) Standard Speed Version)

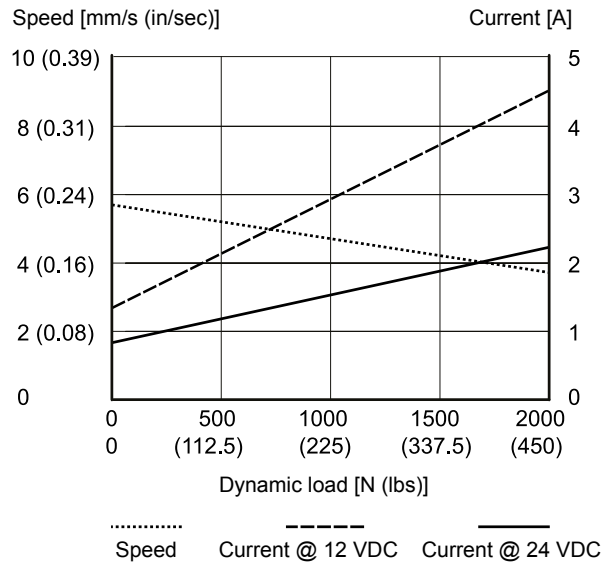

Wxx02-54A - Load vs. Speed / Current
(2000 N (450 lbs) High Speed Version)

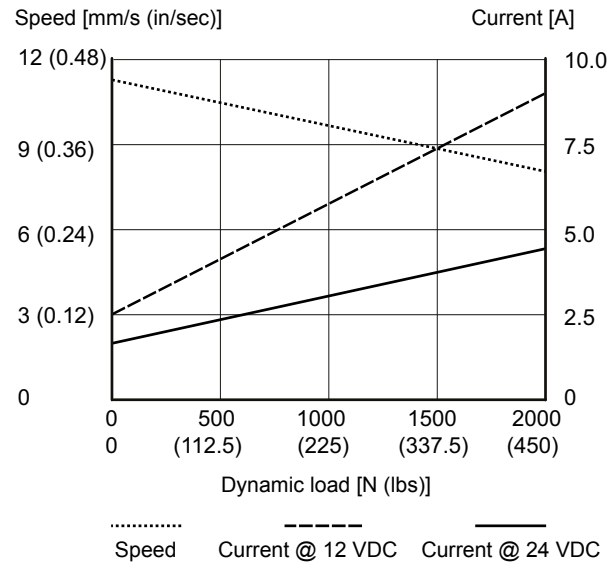

Wxx04-58A - Load vs. Speed / Current
(4000 N (900 lbs) Version)

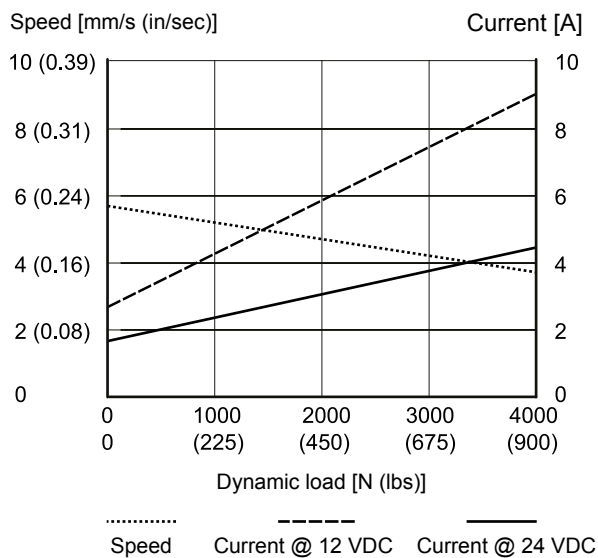

Load Capacity vs. Operating Temperature*

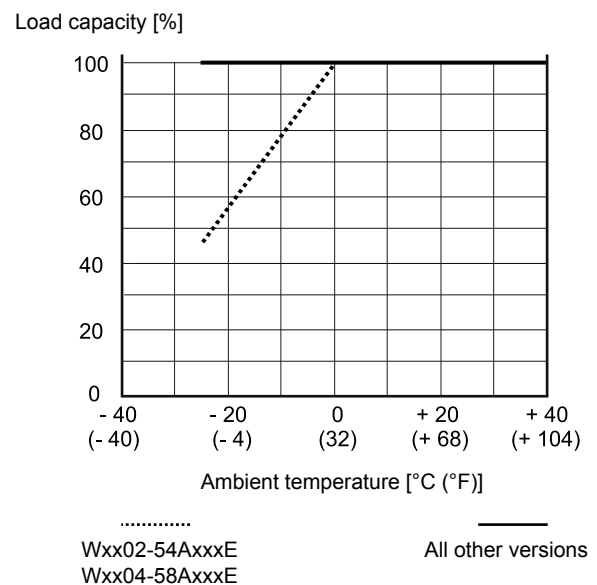

* Most versions have the same load capacity within the permissible operating temperature limits. Two versions however (Wxx02-54AxxxE and Wxx04-58AxxxE) have a reduced capacity at lower temperatures.

5.3 Safety Nut Information

Linear motion/thrust is produced by rotating a screw inside a threaded plastic nut, the nut is attached to the extension tube. As the nut moves up and down the screw, it produces movement of the extension tube and force (thrust).

- This unit is supplied with a metal safety nut which will hold a compression load in the case of complete thread failure of the plastic nut.
- If the threads are lost in the plastic nut, the safety nut engages the lead screw and resolves the load, preventing further actuator movement, requiring actuator replacement.



- The safety nut does not resolve tension loads.

5.4 Cleaning

The following recommended chemicals may be used to clean the surfaces of the actuator:

1. Mild soap and water solution
2. Vinegar and water solution
3. Mild bleach and water solution
4. Household cleaners (window or counter top cleaners).
5. Rubbing alcohol
6. Diluted citric acid cleaners



Under no circumstances is any acetone based solution to be used, as damage to housing or nameplate may occur.

5.5 Ordering Key

Ordering Key								
1	2	3	4	5	6	7	8	9
W12	02-	58A	10	-	N	A	1	B
1. Model and input voltage								
W12 = WhisperTrak™, 12 VDC W24 = WhisperTrak™, 24 VDC								
2. Maximum dynamic force								
02- = 2000 N (450 lbs) 04- = 4000 N (900 lbs)								
3. Rated no load speed								
58A = 5.8 mm/s (standard speed version) 54A = 11.0 mm/s (high speed version, only available for 2000 N version)								
4. Maximum stroke length								
10 = 100 mm 20 = 200 mm 30 = 300 mm 40 = 400 mm 50 = 500 mm								
5. Retracted length								
- = standard retracted length L = retracted length for units with 100 - 300 (400 - 500) mm maximum stroke length = max. stroke + 140 (191) mm								
6. Onboard control options								
N = standard - no electronic control (for use with Thomson DCG Control) X = electronic limit switches (ELS) E = ELS + low level switching P = analog position feedback D = digital feedback Y = ELS + digital feedback Z = ELS + analog position feedback								
7. Type, adapter position ¹ and anti-rotation mechanism								
A = anti-rotation, adapter holes in standard position M = anti-rotation, adapter holes turned 90°								
8. Cable and connector options								
1 = 1 meter long cable with flying leads 3 = 2 meter long cable with Molex type connector 4 = 1 meter long cable with Pac Con type connector on motor leads only								
9. Enclosure color								
B = black W = white								

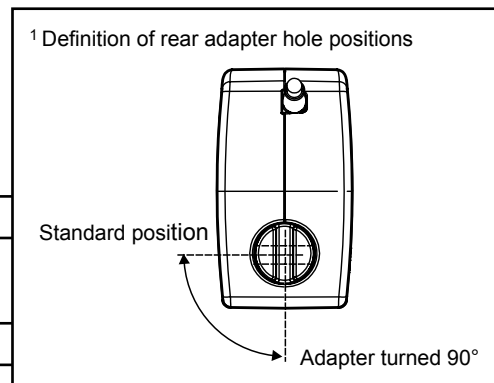

USA, CANADA and MEXICO

Thomson
203A West Rock Road
Radford, VA 24141, USA
Phone: 1-540-633-3549
Fax: 1-540-633-0294
E-mail: thomson@thomsonlinear.com
Literature: literature.thomsonlinear.com

EUROPE**United Kingdom**

Thomson
Office 9, The Barns
Caddsdow Business Park
Bideford, Devon, EX39 3BT
Phone: +44 (0) 1271 334 500
E-mail: sales.uk@thomsonlinear.com

Germany

Thomson
Nürtinger Straße 70
72649 Wolfschlugen
Phone: +49 (0) 7022 504 403
Fax: +49 (0) 7022 504 405
E-mail: sales.germany@thomsonlinear.com

France

Thomson
Phone: +33 (0) 243 50 03 30
Fax: +33 (0) 243 50 03 39
E-mail: sales.france@thomsonlinear.com

Italy

Thomson
Largo Brughetti
20030 Bovisio Masciago
Phone: +39 0362 594260
Fax: +39 0362 594263
E-mail: info@thomsonlinear.it

Spain

Thomson
Rbla Badal, 29-31 7th, 1st
08014 Barcelona
Phone: +34 (0) 9329 80278
Fax: + 34 (0) 9329 80278
E-mail: sales.esm@thomsonlinear.com

Sweden

Thomson
Estridsväg 10
29109 Kristianstad
Phone: +46 (0) 44 24 67 00
Fax: +46 (0) 44 24 40 85
E-mail: sales.scandinavia@thomsonlinear.com

ASIA**Asia Pacific**

E-mail: sales.apac@thomsonlinear.com

China

Thomson
Rm 2205, Scitech Tower
22 Jianguomen Wai Street
Beijing 100004
Phone: +86 400 6661 802
Fax: +86 10 6515 0263
E-mail: sales.china@thomsonlinear.com

India

Thomson
c/o CNRG Energy India Pvt. Ltd.
Unit No. FF A 07
Art Guild House, A Wing, 1st Floor, L.B.S Marg
Kurla – West, Mumbai – 400070 India
Phone: +0091 22 6249 5043
Email: sales.india@thomsonlinear.com

Japan

Thomson
Minami-Kaneden 2-12-23, Suita
Osaka 564-0044
Phone: +81-6-6386-8001
Fax: +81-6-6386-5022
E-mail: csjapan@scgap.com

South Korea

Thomson ROA
704 ASEM Tower (Samsung-dong),
517 Yeongdong-daero,
Gangnam-gu, Seoul, S. Korea (06164)
Phone: +82 2 6917 5048/5049
Fax: +82 2 528 1456/1457
E-mail: sales.korea@thomsonlinear.com

SOUTH AMERICA**Brazil**

Thomson
Av. Tamboré, 1077
Barueri, SP – 06460-000
Phone: +55 (11) 3616-0191
Fax: +55 (11) 3611-1982
E-mail: sales.brasil@thomsonlinear.com

www.thomsonlinear.com

WhisperTrak_Electric_Linear_Actuator_MNEN-0004-06 | 20180119 (DW110685-GB-1803)
Specifications are subject to change without notice. It is the responsibility of the product user to determine the suitability of this product for a specific application. All trademarks property of their respective owners. © 2017 Thomson Industries, Inc.

 **THOMSON**[®]
Linear Motion. Optimized.[™]